

## Horn Metric LS220-4E Specifications

Tube / Pipe Range	Min		Max	
	Imperial	Metric	Imperial	Metric
Round Tube (Minimum & Maximum)	0.709"	18.0 mm	8.66"	220.0 mm
Square Tube (Minimum & Maximum)	0.709"	18.0 mm	6.00"	152.4 mm
Diagonal of Square Tube (Minimum & Maximum)	1.000"	25.4 mm	8.50"	216.0 mm
Rectangular Tube (Minimum & Maximum)	1.000" x 6.00" / 25 mm x 152.4 mm (EW or HW)			
Pipe (IPS)	6" IPS Schedule 80			
Material types	Carbon & stainless steel, AL, & Alloys			

Wall Thickness	Steel	Steel	Stainless Steel
	O <sup>2</sup>	N <sup>2</sup>	N <sup>2</sup>
Maximum wall thickness (2 kW)	.315" / 8mm	.236" / 6mm	.236" / 6mm
Maximum wall thickness (3 kW)	.472" / 12mm	.315" / 8mm	.315" / 8mm
Maximum wall thickness (4 kW)	.630" / 16mm	.393" / 10mm	.393" / 10mm

**Note: If laser cutting speeds are reduced than thicker wall tubes may be cut**

Loading / Unloading	Imperial	Metric	Imperial	Metric
	Tube Loading Options (Standard = 240" / 6096 mm)	120.00"	3048.0 mm	326.7"
Tube Unloading Options (Standard = 120" / 3048.0 mm)	120.00"	3048.0 mm	360.00"	9144.0 mm
Minimum Length of remaining tube (3 chuck system)	3.15" / 80mm			
Maximum Bundle Weight	5,5000 lbs / 2,500 Kg			
Average raw material weight	20.5 lbs / ft or 45 Kg / M			

Axis Stroke / Speed	(Stroke)		(Speed)	
	Imperial	Metric	Imperial	Metric
X-Axis (Laser head horizontal)	10.63"	270 mm	9.85 In / sec	250 mm / sec
Z-Axis (Laser head vertical)	15.12"	384 mm	13.86 In / sec	352 mm / sec
A-Axis (Laser head tilt)	<b>Not Available on 4-Axis</b>		<b>Not Available on 4-Axis</b>	
B1, B2 & B3 Axes (Tube rotation)	+/- 360 Deg		450 Deg / sec	
Y-Axes (Stroke will vary based upon loader length)	N/A		30.60 In / sec	777 mm / sec
Maximum Machine feeding rate	1,835 in/min		46,620 mm / min	
Positioning Accuracy (Travel)	+/- 0.001" / 0.03 mm			
Rotational Accuracy (degrees)	+/- 0.01 Deg			

General Specifications	Description
Laser Power, IPG Fiber Optic	2 kW, 3 kW & 4 kW (Standard = 2 kW)
Chiller system dual loop for laser power & cutting head	Included as standard with laser cutter
Scrap take-away conveyor	Incline conveyor for loading of scrap bin (.37 kW, 0.6 Amps)
Tube length measurement system (servo driven)	Included as standard with laser cutter
Power Requirement	
2 kW Laser (Assumes PF of .80)	480V, 3-Ph, 60 Hz, 18.5 kW, 32 Amps
3 kW Laser (Assumes PF of .80)	480V, 3-Ph, 60 Hz, 26 kW, 35 Amps
4 kW Laser (Assumes PF of .80)	480V, 3-Ph, 60 Hz, 29 kW, 37 Amps
Dual output air compressor (Assumes PF of .80)	Screw compressor with air dryer (15 kW, 23 Amps )
Air Requirement	
Loading, Chucks & Unloading	85 PSI (6 Kg / cm <sup>2</sup> )
Laser Cutting	213 PSI (15 Kg / cm <sup>2</sup> )
Fume collector and filtration	Vacuum system for fume collection (3.73 kW, 6 Amps)

## Horn Metric LS220-4E Floor Plan

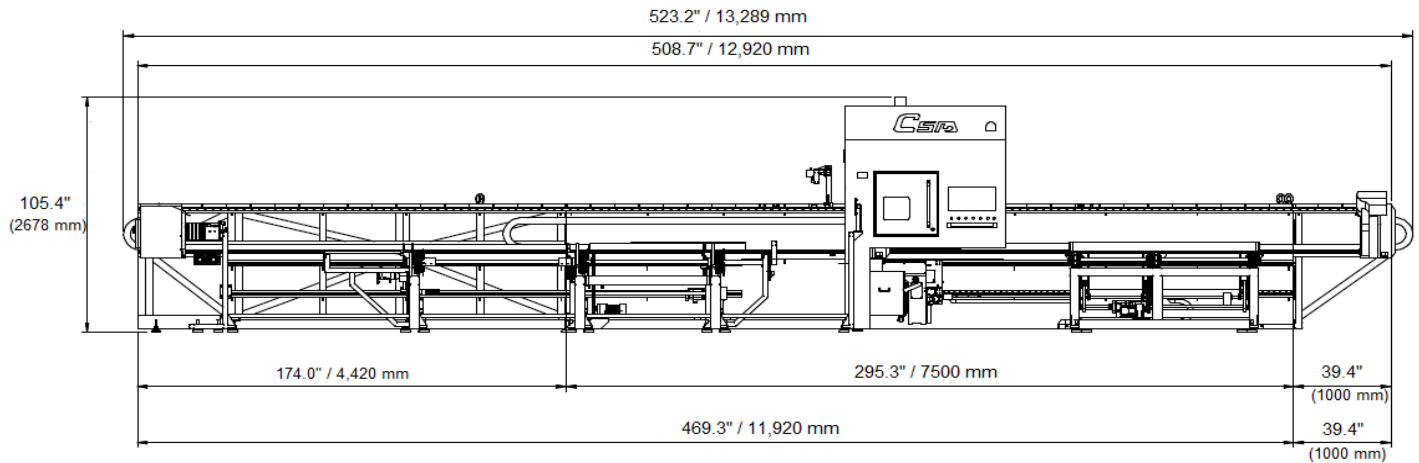

Approximate Dimensions (Laser cutters will vary based upon end-user requirements)

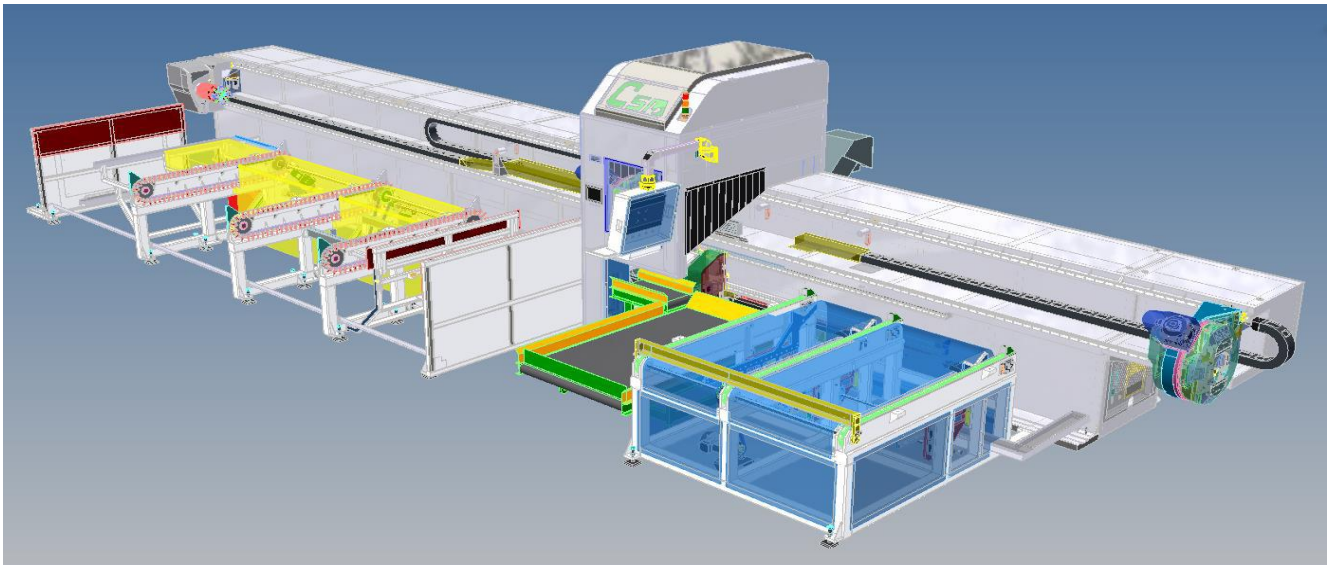

Approximate Front View (Laser cutters will vary based upon end-user requirements)

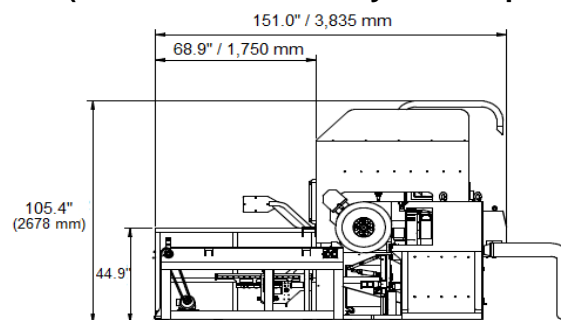

End / Side View (Laser cutters will vary based upon end-user requirements)

**Notes:**

- 1) Dimensions and weights will vary based upon lengths of the loading and unloading systems.
- 2) For lasers in stock, if a voltage system other than 480V, 3-ph is required, a transformer will need to be provided.

**Our Company....."Provides Excellent Results"**