

MADE IN USA TUBE BENDERS | METRIC SERIES TUBE BENDERS | LASER TUBE CUTTERS

Horn Metric LS150-4C Specifications

Tube / Pipe Range	Min		Max	
	Imperial	Metric	Imperial	Metric
Round Tube (Minimum & Maximum)	0.630"	16.0 mm	6.00"	152.4 mm
Square Tube (Minimum & Maximum)	0.630"	16.0 mm	4.00"	101.6 mm
Diagonal of Square Tube (Minimum & Maximum)	.885 "	22.5 mm	6.00"	152.4 mm
Rectangular Tube (Minimum & Maximum)	.630" x 4.00" / 16 mm x 101.6 mm (EW or HW)			
Pipe (IPS)	5" IPS Schedule 80			
Material types	Carbon & stainless steel, AL, & Alloys			

Wall Thickness	Steel	Steel	Stainless Steel
	O ²	N ²	N ²
Maximum wall thickness (2 kW)	.315" / 8mm	.236" / 6mm	.236" / 6mm
Maximum wall thickness (3 kW)	.472" / 12mm	.315" / 8mm	.315" / 8mm
Maximum wall thickness (4 kW)	.630" / 16mm	.393" / 10mm	.393" / 10mm

Note: If laser cutting speeds are reduced than thicker wall tubes may be cut

Loading / Unloading	Min		Max	
	Imperial	Metric	Imperial	Metric
Tube Loading Options (Standard = 240" / 6096 mm)	120.00"	3048.0 mm	326.7"	8300.0 mm
Tube Unloading Options (Standard = 120" / 3048.0 mm)	120.00"	3048.0 mm	360.00"	9144.0 mm
Minimum Length of remaining tube (2 chuck system)	25.5" / 650mm			
Maximum Bundle Weight	4,4000 lbs / 2,000 Kg			
Average raw material weight	12 lbs / ft or 18 Kg / M			

Axis Stroke / Speed	(Stroke)		(Speed)	
	Imperial	Metric	Imperial	Metric
X-Axis (Laser head horizontal)	6.30"	160 mm	9.85 In / sec	250 mm / sec
Z-Axis (Laser head vertical)	12.20"	310 mm	13.86 In / sec	352 mm / sec
A-Axis (Laser head tilt)	Not available on 4-Axis		Not available on 4-Axis	
B1, B2 & B3 Axes (Tube rotation)	+/- 360 Deg		600 Deg / sec	
Y-Axes (Stroke will vary based upon loader length)	N/A		30.60 In / sec	777 mm / sec
Maximum Machine feeding rate	1,835 in/min		46,620 mm / min	
Positioning Accuracy (Travel)	+/- 0.001" / 0.03 mm			
Rotational Accuracy (degrees)	+/- 0.01 Deg			

General Specifications	Description
Laser Power, IPG Fiber Optic	2 kW or 3 kW (Standard = 2 kW)
Chiller system dual loop for laser power & cutting head	Included as standard with laser cutter
Scrap take-away conveyor	Incline conveyor for loading of scrap bin (.37 kW, 0.6 Amps)
Tube length measurement system (servo driven)	Included as standard with laser cutter
Power Requirement	
2 kW Laser (Assumes PF of .80)	480V, 3-Ph, 60 Hz, 18.5 kW, 24 Amps
3 kW Laser (Assumes PF of .80)	480V, 3-Ph, 60 Hz, 26 kW, 32 Amps
4 kW Laser (Assumes PF of .80)	480V, 3-Ph, 60 Hz, 29 kW, 35 Amps
Dual output air compressor (Assumes PF of .80)	Screw compressor with air dryer (15 kW, 23 Amps)
Air Requirement	
Loading, Chucks & Unloading	85 PSI (6 Kg / cm ²)
Laser Cutting	213 PSI (15 Kg / cm ²)
Fume collector and filtration	Vacuum system for fume collection (3.73 kW, 6 Amps)

Horn Metric LS150-4C Semi-Auto Floor Plan

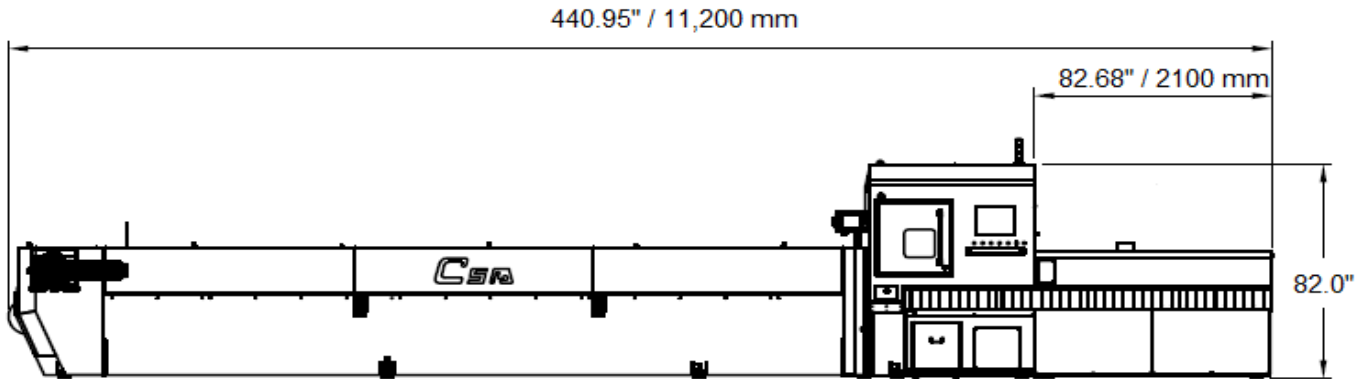

Front View 150LS-4C, Loader = 20' (240"), Un-loader = 10' (120")

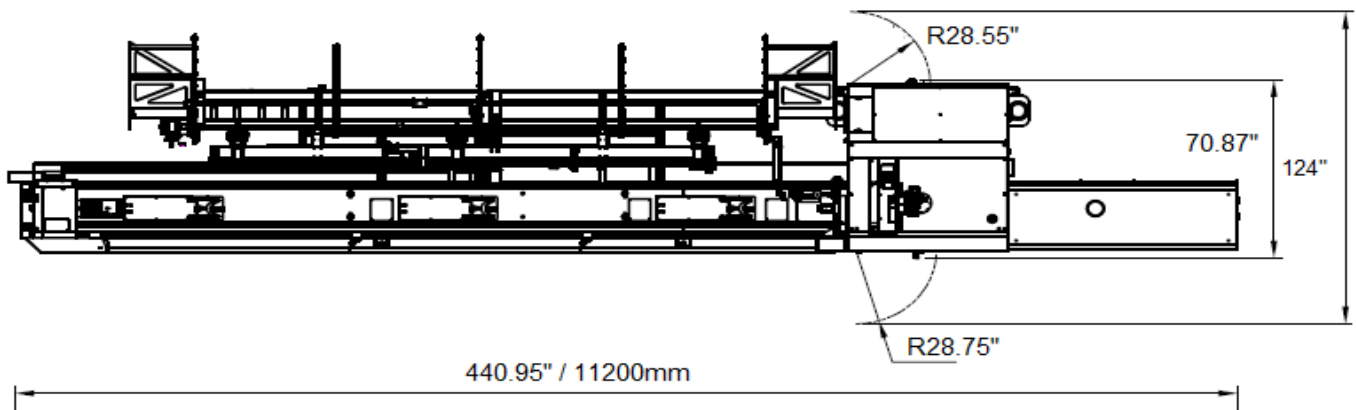

Top View 150LS-4C, Loader = 20' (240"), Un-loader = 10' (120")

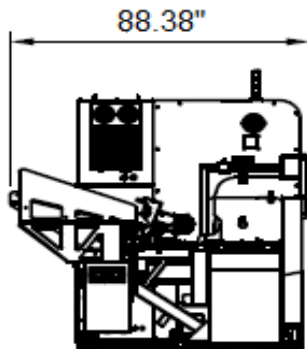

Side View 150LS-4C

Notes:

- 1) Dimensions and weights will vary based upon lengths of the loading and unloading systems.
- 2) For lasers in stock, if a voltage system other than 480V, 3-ph is required, a transformer will need to be provided.

Our Company....."Provides Excellent Results"